

CHECK AND METERING VALVE FLANGEABLE

A-VBC-33-FC

08.47.84 - X - Y - Z

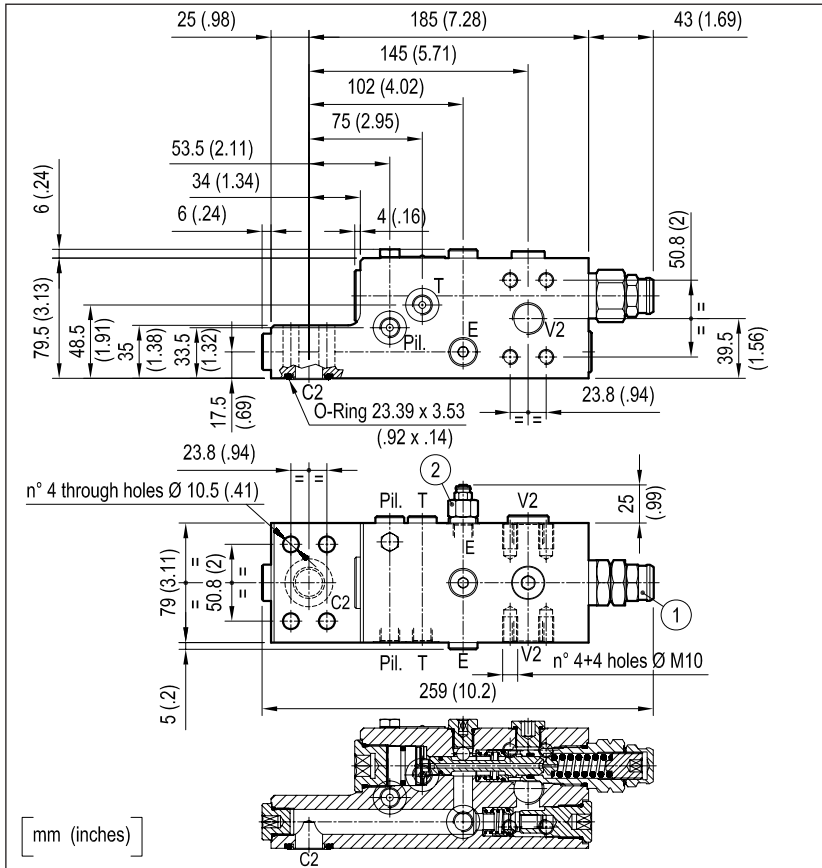

Upstream flow (V2 - C2) to the cylinder is free through the 2 check valves, and reverse flow (C2 - V2) is locked/metered by a leak free spool (1) which provides fine metering in the initial opening stroke. The spool, normally held closed by an adjustable spring force, is remotely controlled by joystick pilot pressure; the pilot pressure required to move the spool is load independent because the spring is vented to Tank. The valve includes a small relief cartridge (2) which senses C2 pressure and opens under overload or shock conditions in order to pilot wide open the metering spool and to allow cylinder pressure to be relieved downstream through the main hose (V2) and through the main control valve.

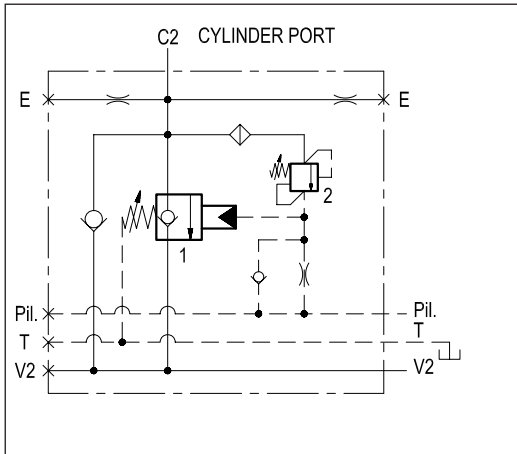

TECHNICAL DATA

Max. operating pressure: 420 bar (6000 psi)

Max flow: 250 l/min (66 gpm)

Steel body

Weight: 8 kg (17.6 lbs)

This valve is designed to be flange mounted on boom cylinders of hydraulic excavators, and, with specific adjustments, it can become part of load holding and load lowering systems designed to comply with ISO Standard 8643 (hose burst protection).

Note: the Tank vented port must be connected to a "low pressure tank line" (to the joystick tank line, or to tank directly).

The restricted "E" port must be connected to a "pressure equalizing line" in case of 2 valves fitted to 2 twin cylinders, and may be used as "outlet to tank" for emergency boom lowering in case of pilot pressure failure.

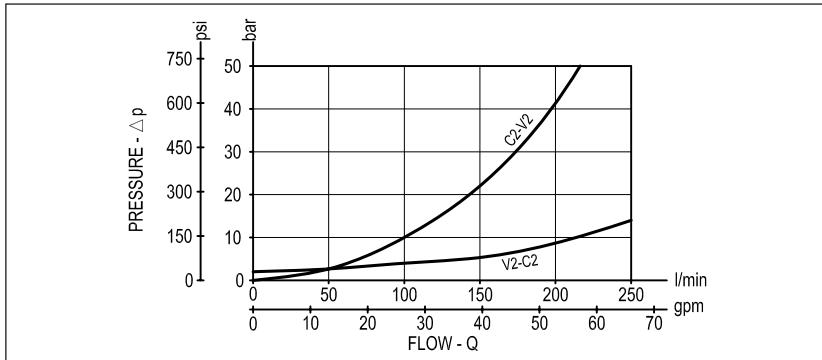

X	ADJUSTMENTS	
03	Leakproof inner hex. socket screw	

Z	SPRINGS					
	Adj. press. range bar (psi)	Pres. increase bar/turn (psi/turn)	Std. setting bar (psi)	Ordering code	Colour	
40	Valve 1	3-15 (45-220)	5 (73)	7.5 (109) "cracking"	03.51.01.184	yellow
	Valve 2	350-460 (5000-6600)	228 (3306)	350 (5000) "5 l/min"		

Y	PORT SIZE	
	V2-C2	E-Pil-T
72	3/4" SAE 6000	G 1/4